

This Page Is Inserted by IFW Operations
and is not a part of the Official Record

BEST AVAILABLE IMAGES

Defective images within this document are accurate representations of the original documents submitted by the applicant.

Defects in the images may include (but are not limited to):

- BLACK BORDERS
- TEXT CUT OFF AT TOP, BOTTOM OR SIDES
- FADED TEXT
- ILLEGIBLE TEXT
- SKEWED/SLANTED IMAGES
- COLORED PHOTOS
- BLACK OR VERY BLACK AND WHITE DARK PHOTOS
- GRAY SCALE DOCUMENTS

IMAGES ARE BEST AVAILABLE COPY.

**As rescanning documents *will not* correct images,
please do not report the images to the
Image Problem Mailbox.**

PCT

WORLD INTELLECTUAL PROPERTY ORGANIZATION
International Bureau

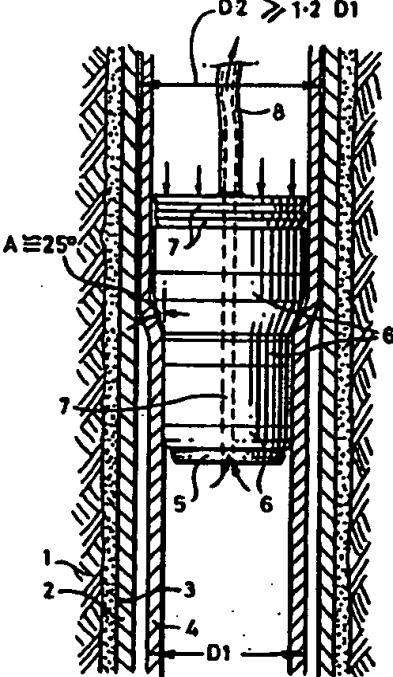

INTERNATIONAL APPLICATION PUBLISHED UNDER THE PATENT COOPERATION TREATY (PCT)

<p>(51) International Patent Classification⁶ : E21B 43/10, 29/10, 17/00, C21D 7/12, B21D 39/20</p>	<p>A1</p>	<p>(11) International Publication Number: WO 98/00626 (43) International Publication Date: 8 January 1998 (08.01.98)</p>
<p>(21) International Application Number: PCT/EP97/03489 (22) International Filing Date: 30 June 1997 (30.06.97) (30) Priority Data: 96201809.9 1 July 1996 (01.07.96) EP (34) Countries for which the regional or international application was filed: GB et al. (71) Applicant (for all designated States except CA): SHELL INTERNATIONALE RESEARCH MAATSCHAPPIJ B.V. [NL/NL]; Maatschappij B.V., Carel van Bylandtlaan 30, NL-2596 HR The Hague (NL). (71) Applicant (for CA only): SHELL CANADA LTD. [CA/CA]; 400 - 4th Avenue, S.W., Calgary, Alberta T2P 2H5 (CA). (72) Inventors: DONNELLY, Martin; Badhuisweg 3, NL-1031 CM Amsterdam (NL). FAURE, Alban, Michel; Volmerlaan 6, NL-2288 GD Rijswijk (NL). MARKETZ, Franz; Volmerlaan 6, NL-2288 GD Rijswijk (NL). STEWART, Robert, Bruce; Volmerlaan 6, NL-2288 GD Rijswijk (NL). LOHBECK, Wilhelmus, Christianus, Maria; Volmerlaan 6, NL-2288 GD Rijswijk (NL).</p>	<p>(81) Designated States: AL, AM, AT, AU, AZ, BA, BB, BG, BR, BY, CA, CH, CN, CU, CZ, DE, DK, EE, ES, FI, GB, GE, GH, HU, IL, IS, JP, KE, KG, KP, KR, KZ, LC, LK, LR, LS, LT, LU, LV, MD, MG, MK, MN, MW, MX, NO, NZ, PL, PT, RO, RU, SD, SE, SG, SI, SK, SL, TJ, TM, TR, TT, UA, UG, UZ, VN, YU, ZW, ARIPO patent (GH, KE, LS, MW, SD, SZ, UG, ZW), Eurasian patent (AM, AZ, BY, KG, KZ, MD, RU, TJ, TM), European patent (AT, BE, CH, DE, DK, ES, FI, FR, GB, GR, IE, IT, LU, MC, NL, PT, SE), OAPI patent (BF, BJ, CF, CG, CI, CM, GA, GN, ML, MR, NE, SN, TD, TG).</p> <p>Published With international search report.</p>	
<p>(54) Title: METHOD FOR EXPANDING A STEEL TUBING AND WELL WITH SUCH A TUBING</p>		
<p>(57) Abstract</p> <p>A tubing (4) made of a formable steel grade which is subject to strain hardening without incurring any necking or ductile fracturing as a result of the expansion process is expanded by moving an expansion mandrel (5) having a non-metallic tapering outer surface through the tubing, thereby increasing the strength of the tubing while expansion forces remains low.</p> 		

FOR THE PURPOSES OF INFORMATION ONLY

Codes used to identify States party to the PCT on the front pages of pamphlets publishing international applications under the PCT.

AL	Albania	ES	Spain	LS	Lesotho	SI	Slovenia
AM	Armenia	FI	Finland	LT	Lithuania	SK	Slovakia
AT	Austria	FR	France	LU	Luxembourg	SN	Senegal
AU	Australia	GA	Ghana	LV	Latvia	SE	Sweden
AZ	Azerbaijan	GB	United Kingdom	MC	Monaco	TD	Chad
BA	Bosnia and Herzegovina	GE	Georgia	MD	Republic of Moldova	TG	Togo
BB	Barbados	GH	Ghana	MG	Madagascar	TJ	Tajikistan
BE	Belgium	GN	Guinea	MK	The Former Yugoslav Republic of Macedonia	TM	Turkmenistan
BF	Burkina Faso	CR	Costa Rica	ML	Mali	TR	Turkey
BG	Bulgaria	HU	Hungary	MN	Mongolia	TT	Trinidad and Tobago
BJ	Benin	IE	Ireland	MR	Mauritania	UA	Ukraine
BR	Brazil	IL	Israel	MW	Malawi	UG	Uganda
BY	Belarus	IS	Iceland	MX	Mexico	US	United States of America
CA	Canada	IT	Italy	NE	Niger	UZ	Uzbekistan
CF	Central African Republic	JP	Japan	NL	Netherlands	VN	Viet Nam
CG	Congo	KE	Kenya	NO	Norway	YU	Yugoslavia
CH	Switzerland	KG	Kyrgyzstan	NZ	New Zealand	ZW	Zimbabwe
CI	Côte d'Ivoire	KP	Democratic People's Republic of Korea	PL	Poland		
CM	Cameroon	KR	Republic of Korea	PT	Portugal		
CN	China	KZ	Kazakhstan	RO	Romania		
CU	Cuba	LC	Saint Lucia	RU	Russian Federation		
CE	Czech Republic	LJ	Liechtenstein	SD	Sudan		
DE	Germany	LK	Sri Lanka	SE	Sweden		
DK	Denmark	LR	Liberia	SG	Singapore		
EE	Estonia						

METHOD FOR EXPANDING A STEEL TUBING AND WELL WITH SUCH A TUBING

The invention relates to expansion of tubings. More particularly the invention relates to a method of expanding a steel tubing by moving an expansion mandrel through the tubing.

5 Numerous methods and devices are known for expansion of tubings.

European patent specification 643794 discloses a method of expanding a casing against the wall of an underground borehole wherein the casing is made of a
10 malleable material which preferably is capable of plastic deformation of at least 25% uniaxial strain and the casing may be expanded by an expansion mandrel which is pumped, pulled or pushed through the casing.

Other expansion methods and devices are disclosed in
15 German patent specification No. 1583992 and in US patent specification Nos. 3,203,483; 3,162,245; 3,167,122; 3,326,293; 3,785,193; 3,489,220; 5,014,779; 5,031,699; 5,083,608 and 5,366,012.

Many of the known expansion methods employ an
20 initially corrugated tube and the latter prior art reference employs a slotted tube which is expanded downhole by an expansion mandrel.

The use of corrugated or slotted pipes in the known methods serves to reduce the expansion forces that need
25 to be exerted to the tube to create the desired expansion.

It is an object of the present invention to provide a method for expanding an at least partly solid, i.e. unslotted, tubing which requires exertion of a low force

to expand the tubing and which provides a tubing having a larger diameter and higher strength than the unexpanded tubing and which can be carried out with a tubing which already may have a tubular shape before expansion.

5 The method according to the invention thereto comprises the step of moving an expansion mandrel through the tubing thereby plastically expanding the tubing, wherein an at least partly solid tubing is expanded which is made of a formable steel grade which is subject to
10 strain hardening without incurring any necking and ductile fracturing as a result of the expansion process and an expansion mandrel is used which has along at least part of its length a tapering non-metallic surface.

 As a result of strain hardening the tubing becomes
15 stronger during the expansion process since for any further increment of expansion always a higher stress is required than for the preceding expansion.

 It has been found that the use of a formable steel grade for the tubing in combination with a non-metallic tapering surface of the expansion mandrel has a synergetic effect since the resulting expanded tubing will have an adequately increased strength while the expansion forces remain low. The low yield strength and high ductility of the tubing before expansion enables, if the
20 tubing is to be used in an underground borehole, the use of a tubing which is reeled from a reeling drum into the borehole.

 It is observed that in the art of metallurgy the terms strain-hardening and work-hardening are synonyms
25 and are both used to denote an increase of strength caused by plastic deformation.

 The term formable steel grade as used in this specification means that the tubing is able to maintain

its structural integrity while being plastically deformed into various shapes.

5 Ways of determining forming characteristics of a steel are set out in the Metals Handbook, 9th edition, volume 14, Forming and Forging, issued by ASM International, Metals Park, Ohio (USA).

10 The term necking refers to a geometrical effect leading to non-uniform plastic deformations at some location by occurrence of a local constriction. From the point of necking on, the continual work hardening in the necked region no longer compensates for the continual reduction of the smallest cross-section in the neck, and therefore, the load carrying capacity of the steel decreases. With continuing loading, practically all further plastic deformation is restricted to the region of the neck, so that a highly non-uniform deformation occurs to develop in the necked region until fracture occurs.

20 The term ductile fracturing means that a failure occurs if plastic deformation of a component that exhibits ductile behaviour is carried to the extreme so that the component separates locally into two pieces. Nucleation, growth and coalescence of internal voids propagate to failure, leaving a dull fibrous rupture surface. A detailed description of the terms necking and ductile fracturing is given in the handbook "Failure of Materials in Mechanical Design" by J.A. Collins second edition, issued by John Wiley and Sons, New York (USA) in 1993.

30 Preferably the tubing is made of a high-strength steel grade with formability and having a yield strength-tensile strength ratio which is lower than 0.8 and a yield strength of at least 275 MPa. When used in this

specification, the term high-strength steel denotes a steel with a yield strength of at least 275 MPa.

It is also preferred that the tubing is made of a formable steel grade having a yield stress/tensile stress ratio which is between 0.6 and 0.7.

Dual phase (DP) high-strength, low-alloy (HSLA) steels lack a definite yield point which eliminates Luders band formation during the tubular expansion process which ensures good surface finish of the expanded tubular.

Suitable HSLA dual phase (DP) steels for use in the method according to the invention are grades DP55 and DP60 developed by Sollac having a tensile strength of at least 550 Mpa and grades SAFH 540 D and SAFH 590 D developed by Nippon Steel Corporation having a tensile strength of at least 540 MPa.

Other suitable steels are the following formable high-strength steel grades

- an ASTM A106 high-strength low alloy (HSLA) seamless pipe;
- an ASTM A312 austenitic stainless steel pipe, grade TP 304 L;
- an ASTM A312 austenitic stainless steel pipe, grade TP 316 L; and
- a high-retained austenite high-strength hot-rolled steel (low-alloy TRIP steel) such as grades SAFH 590 E, SAFH 690 E and SAFH 780 E developed by Nippon Steel Corporation.

The above-mentioned DP and other suitable steels each have a strain hardening exponent n of at least 0.16 which allows an expansion of the tubing such that the external diameter of the expanded tubing is at least 20% larger than the external diameter of the unexpanded tubing.

Detailed explanations of the terms strain hardening, work hardening and the strain hardening exponent n are given in chapters 3 and 17 of the handbook "Metal Forming-Mechanics and Metallurgy", 2nd edition, issued by
5 Prentice Hall, New Jersey (USA), 1993.

Suitably, the expansion mandrel contains an expansion section that has a conical ceramic outer surface. If the expansion mandrel is pumped through the tubing then the mandrel preferably comprises a sealing section which is
10 located at such a distance from the tapering expansion section that when the expansion mandrel is moved through the tubing by means of exerting a hydraulic pressure behind the mandrel the sealing section engages a
15 plastically expanded part of the tubing. This will generally be achieved if said distance is at least three times the wall thickness of the expanded tubing.

The use of a ceramic conical surface reduces friction forces during the expansion process and by having a sealing section which engages the expanded tube it is
20 avoided that hydraulic forces would result in an excessive expansion of the tubing.

In such case it is preferred that the expansion mandrel contains a vent line for venting to the surface any fluids that are present in the borehole and tubing
25 ahead of the expansion mandrel.

Alternatively the tubing is expanded such that the outer diameter of the expanded tubing is slightly smaller than the internal diameter of the borehole or of any casing that is present in the borehole and any fluids
30 that are present in the borehole and tubing ahead of the expansion mandrel are vented to surface via the annular space that remains open around the tubing after the expansion process.

The invention also relates to a well provided with a tubing which is expanded using the method according to the invention. In such case the tubing may serve as production tubing through which hydrocarbon fluid is transported to the surface and a reelable service and/or kill line passes through at least a substantial part of the length of the tubing, through which line fluid can be pumped towards the bottom of the borehole while hydrocarbon fluid is produced via the surrounding production tubing. The use of such an expanded production tubing allows the use of almost the full wellbore for the transport of hydrocarbon fluids so that a relatively slim borehole may be utilized to attain the desired production rate.

Alternatively the tubing may be expanded against the inner surface of a casing which is present in the borehole. In such case the tubing may either be used as a production tubing and/or as a protective cladding for protecting the well casing against corrosive well fluids and damage from tools that may be lowered into the well during maintenance and workover operations.

These and other objects, features and advantages of the method and well system according to the present invention will be apparent from the accompanying claims, abstract and the following detailed description with reference to the accompanying drawing, in which Fig. 1 is schematic longitudinal sectional view of an underground borehole in which a tubing is expanded in accordance with the method according to the invention.

Now referring to Fig. 1, there is shown a borehole traversing an underground formation 1 and a casing 2 that is fixed within the borehole by means of an annular body of cement 3.

2

3

5

A production tubing 4 which is made of a dual phase, high-strength low-alloy (HSLA) steel or other formable high-strength steel is suspended within the casing 2.

5 An expansion mandrel 5 is moved in longitudinal direction through the tubing 4 thereby expanding the tubing 4 such that the outer diameter of the expanded tubing is slightly smaller than or is about equal to the internal diameter of the casing 2.

10 The expansion mandrel 5 is equipped with a series of ceramic surfaces 6 which restrict frictional forces between the pig and tubing 4 during the expansion process. In the example shown the semi top angle A of the conical ceramic surface that actually expands the tubing is about 25°. It has been found that zirconium oxide is a suitable ceramic material which can be formed as a smooth
15 conical ring. Experiments and simulations have shown that if the semi cone top angle A is between 20° and 30° the pipe deforms such that it obtains an S-shape and touches the tapering part of the ceramic surface 6 essentially at
20 the outer tip or rim of said conical part and optionally also about halfway the conical part.

The experiments also showed that it is beneficial that the expanding tubing 4 obtains an S-shape since this reduces the length of the contact surface between the
25 tapering part of the ceramic surface 6 and the tubing 4 and thereby also reduces the amount of friction between the expansion mandrel 5 and the tubing 4.

30 Experiments have also shown that if said semi top angle A is smaller than 15° this results in relatively high frictional forces between the tube and pig, whereas is said top angle is larger than 30° this will involve redundant plastic work due to plastic bending of the tubing 4 which also leads to higher heat dissipation and

to disruptions of the forward movement of the pig 5 through the tubing 4. Hence said semi top angle A is preferably selected between 15° and 30° and should always be between 5° and 45°.

5 Experiments have also shown that the tapering part of the expansion mandrel 5 should have a non-metallic outer surface to avoid galling of the tubing during the expansion process. The use of a ceramic surface for the tapering part of the expansion mandrel furthermore caused
10 the average roughness of the inner surface of the tubing 4 to decrease as a result of the expansion process. The experiments have also shown that the expansion mandrel 5 provided with a ceramic tapering surface 6 could expand a tubing 5 made of a formable
15 steel such that the outer tubing diameter D2 after expansion was at least 20% larger than the outer diameter D1 of the unexpanded tubing and that suitable formable steels are dual phase (DP) high-strength low alloy (HSLA) steels known as DP55 and DP60; ASTM A106 HSLA seamless
20 pipe, ASTM A312 austenitic stainless steel pipes, grades TP 304 L and TP 316 L and a high-retained austenite high-strength hot rolled steel, known as TRIP steel manufactured by the Nippon Steel Corporation.

The mandrel 5 is provided with a pair of sealing
25 rings 7 which are located at such a distance from the conical ceramic surface 6 that the rings 7 face the plastically expanded section of the tubing 4. The sealing rings serve to avoid that fluid at high hydraulic pressure would be present between the conical ceramic
30 surface 6 of the mandrel 5 and the expanding tubing 4 which might lead to an irregularly large expansion of the tubing 4.

The expansion mandrel 5 is provided with a central vent passage 7 which is in communication with a coiled vent line 8 through which fluid may be vented to the surface. After completion of the expansion process the pig 5 may be pulled up to surface by the vent line and a coiled kill and/or service line (not shown) may be lowered into the expanded tubing 4 to facilitate injection of kill and/or treatment fluids towards the hydrocarbon fluid inflow zone which is normally done via the annulus between the production tubing and the well casing. However, if the tubing 4 is expanded to a smaller diameter then the residual annular space between the casing 2 and expanded tubing 4 can be used for venting of fluids during the expansion process and for injection of fluids during the production process, in which case there is no need for using a vent line 8 and kill and/or service lines.

In conventional wells it is often necessary to use a production tubing having an outer diameter which is less than 50% of the inner diameter of the well casing to enable a smooth insertion of the tubing even if the well is deviated and the casing has an irregular inner surface. Therefore it is apparent that the in-situ tubing expansion method according to the present invention enhances an efficient use of the wellbore.

It will be understood that instead of moving the expansion mandrel through the tubing by means of hydraulic pressure, the mandrel can also be pulled through the tubing by means of a cable or pushed through the tubing by means of pipe string or rod.

The method according to the invention can also be used to expand tubings that are used outside a wellbore, for example to expand oilfield tubulars at surface

facilities or to expand a tubing inside an existing tubing which has been damaged or corroded.

The invention will now be further described on the basis of the following comparative experiments.

5 Experiment 1

 An expansion mandrel having a conical ceramic surface (semi top angle A of cone = 20°) was moved through a conventional oil field tubular, known as casing grade L80 13% Cr, which is a widely used casing type, having an
10 initial outer diameter of 101.6 mm (4"), an initial wall thickness of 5.75 mm, a burst pressure of 850 bar and a strain hardening exponent $n = 0.075$. The expansion
15 mandrel was designed such that the outer diameter of the expanded tubular would be 127 mm, so that the increase in diameter would be 20%. The tubular burst during the
 expansion process. Analysis showed that the ductility limit of the material had been exceeded so that ductile fracturing occurred.

Experiment 2

20 An experiment was carried out with a coiled tubing of the type QT-800 which is increasingly used as a production tubing in oil or gas wells. The tubing had an
 initial outer diameter of 60.3 mm, a wall thickness of 5.15 mm, a burst pressure of 800 bar and a strain
25 hardening exponent $n = 0.14$. An expansion mandrel was moved through the tubing which mandrel comprised a
 conical ceramic surface such that the semi top angle A of a cone enveloping the conical surface was 5° and which
30 was designed such that the outer diameter of the expanded tubing would be 73 mm (increase of about 21%). This
 tubing burst during the expansion process. Analysis revealed that due to high friction forces the expansion

pressure had exceeded the burst pressure of the pipe during the expansion process.

Experiment 3

5 An experiment was carried out with a seamless pipe made of a formable steel grade known as ASTM A 106 Grade B. The pipe had an initial outer diameter of 101.6 mm (4"), an initial wall thickness of 5.75 mm and a strain hardening exponent $n = 0.175$.

10 An expansion mandrel was pumped through the pipe, which mandrel comprised a ceramic conical surface such that the semi top angle A of a cone enveloping the conical surface was 20° and such that the outer diameter of the expanded pipe was 127 mm (5") and the outer diameter increased by 21%.

15 The pipe was expanded successfully and the hydraulic pressure exerted to the mandrel to move the mandrel through the pipe was between 275 and 300 bar. The burst pressure of the expanded pipe was between 520 and 530 bar.

C L A I M S

1. A method of expanding a steel tubing, the method comprising the step of moving an expansion mandrel through the tubing thereby plastically expanding the tubing, wherein an at least partly solid tubing is expanded which is made of a formable steel grade which is subject to strain hardening without incurring any necking and ductile fracturing as a result of the expansion process and an expansion mandrel is used which has along at least part of its length a tapering non-metallic surface.
2. The method of claim 1, wherein the tubing is made of a formable steel grade having a yield strength-tensile strength ratio which is lower than 0.8 and a yield strength of at least 275 MPa.
3. The method of claim 1 or 2, wherein the tubing is made of a steel having a yield strength-tensile strength ratio which is between 0.6 and 0.7.
4. The method of claim 1, 2 or 3, wherein the tubing is made of a dual phase (DP) high-strength low alloy (HSLA) steel.
5. The method of claim 4, wherein the tubing is made of Sollac grade DP55 or DP60 having a tensile strength of at least 550 Mpa or Nippon grade SAFH 540 D or SAFH 590 D.
6. The method of claim 1, 2 or 3 wherein the tubing is made of a formable high-strength steel grade which is selected from the following group of steel grades:
- an ASTM A106 high-strength low alloy (HSLA) seamless pipe;

- an ASTM A312 austenitic stainless steel pipe, grade TP 304 L;
 - an ASTM A312 austenitic stainless steel pipe, grade TP 316 L; and
- 5 - a high-retained austenite high-strength hot rolled steel which is known as TRIP steel.
7. The method of any preceding claim, wherein the tubing is expanded such that the external diameter of the expanded tubing is at least 20% larger than the external diameter of the unexpanded tubing and wherein the strain hardening exponent n of the formable steel of the tubing is at least 0.16.
- 10 8. The method of any preceding claim, wherein the expansion mandrel comprises a tapering expansion section which has a smooth ceramic outer surface which is oriented at an acute angle A which is between 5° and 45° with respect to a longitudinal axis of the mandrel and which induces the tubing to expand without inducing any galling of the tubing and such that the average roughness of the inner surface of the tubing decreases as a result of the expansion process.
- 15 9. The method of claim 8, wherein the ceramic outer surface of the tapering expansion section is made of zirconium oxide and is oriented at an acute angle A which is between 15° and 30° with respect to a longitudinal axis of the mandrel.
- 20 11. The method of any preceding claim, wherein the tubing is expanded by pumping the expansion mandrel through the tubing.
- 25 12. The method of claim 7 and 11, wherein the expansion mandrel comprises a sealing section which is located at such a distance from the expansion section that when the expansion mandrel is pumped through the tubing the
- 30
-

sealing section engages a plastically expanded part of the tubing.

5 13. The method of claim 11 or 12, wherein the tubing is expanded inside an underground borehole and the expansion mandrel contains a vent line for venting any fluids that are present in the tubing ahead of the expansion mandrel to the surface.

10 14. The method of claim 11 or 12, wherein the tubing is expanded inside an underground borehole such that the outer diameter of the expanded tubing is slightly smaller than the internal diameter of the borehole or of any casing that is present in the borehole and any fluids that are present in the borehole and tubing ahead of the expansion mandrel are vented to surface via the annular space that remains open around the tubing after the expansion process.

15 15. The method of any preceding claim, wherein the tubing is lowered into an underground borehole after reeling the tubing from a reeling drum.

20 16. A well provided with a tubing which is expanded using the method of any preceding claim, wherein the tubing serves as a production tubing through which hydrocarbon fluid is transported to the surface and a reelable service and/or kill line passes through at least a
25 substantial part of the length of the interior of the tubing, through which line fluid can be pumped towards the bottom of the borehole while hydrocarbon fluid is produced via the surrounding production tubing.

30 17. A well provided with a tubing which is expanded using the method according to any one of claims 1-13, wherein the tubing is expanded against the inner surface of a casing which is present in the borehole.

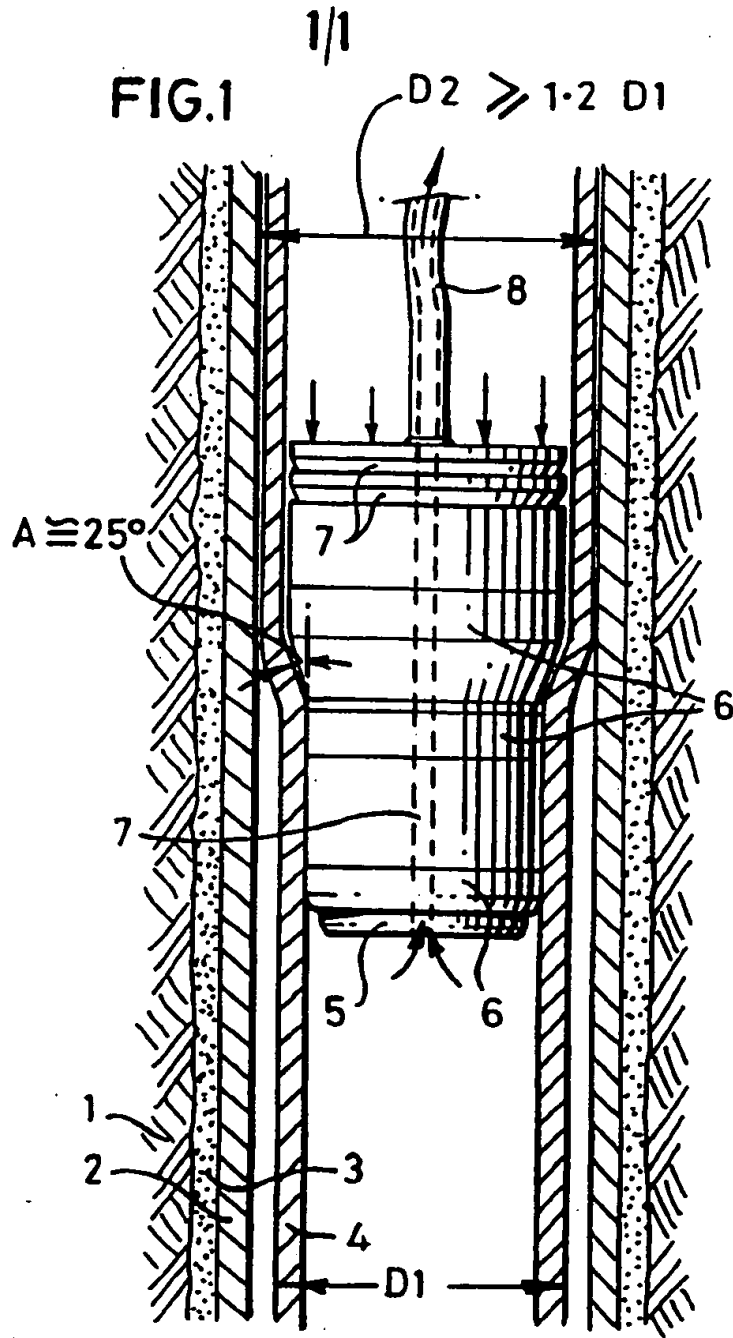

INTERNATIONAL SEARCH REPORT

International Application No.
PCT/EP 97/03489

A. CLASSIFICATION OF SUBJECT MATTER IPC 6 E21B43/10 E21B29/10 E21B17/00 C21D7/12 B21039/20		
According to International Patent Classification (IPC) or to both national classification and IPC		
B. FIELDS SEARCHED Minimum documentation searched (classification system followed by classification symbols) IPC 6 E21B C21D B21C B21D		
Documentation searched other than minimum documentation to the extent that such documents are included in the fields searched		
Electronic data base consulted during the international search (name of data base and, where practicable, search terms used)		
C. DOCUMENTS CONSIDERED TO BE RELEVANT		
Category *	Citation of document, with indication, where appropriate, of the relevant passages	Relevant to claim No.
A	US 4 533 405 A (SPONSELLER) 6 August 1985 see column 1, line 15 - line 27 see column 2, line 67 - column 3, line 2 see column 4, line 26 - line 29 see column 14, line 47 - line 51 see column 17, line 25 - line 27 ---	1
A	CH 180 467 A (THEINTZ) 16 January 1936 see page 1, right-hand column, line 17 - line 19 ---	1
A	US 4 938 266 A (TOMITA) 3 July 1990 see the whole document --- <div style="text-align: right;">-/--</div>	1
<input checked="" type="checkbox"/> Further documents are listed in the continuation of box C. <input checked="" type="checkbox"/> Patent family members are listed in annex.		
* Special categories of cited documents :		
"A" document defining the general state of the art which is not considered to be of particular relevance "E" earlier document but published on or after the international filing date "L" document which may throw doubts on priority claims or which is cited to establish the publication date of another claim or other special reason (as specified) "O" document referring to an oral disclosure, use, exhibition or other means "P" document published prior to the international filing date but later than the priority date claimed		
"T" later document published after the international filing date or priority date and not in conflict with the application but cited to understand the principles or theory underlying the invention "X" document of particular relevance; the claimed invention cannot be considered novel or cannot be considered to involve an inventive step when the document is taken alone "Y" document of particular relevance; the claimed invention cannot be considered to involve an inventive step when the document is considered with one or more other such documents, each combination being obvious to a person skilled in the art "Z" document member of the same patent family		
Date of the actual completion of the international search <div style="text-align: center; font-weight: bold;">30 September 1997</div>		Date of mailing of the international search report <div style="text-align: center; font-weight: bold;">08.10.97</div>
Name and mailing address of the ISA European Patent Office, P.O. 5818 Patentamt 2 NL - 2280 HV Rijswijk Tel. (+31-70) 340-2040, Tx. 31 651 epo nl, Fax: (+31-70) 340-3016		Authorized officer <div style="text-align: center; font-weight: bold;">Sogno, M</div>

INTERNATIONAL SEARCH REPORT

Inter. Application No
PCT/EP 97/03489

C.(Continuation) DOCUMENTS CONSIDERED TO BE RELEVANT		
Category	Citation of document, with indication, where appropriate, of the relevant passages	Relevant to claim No.
A	WO 93 25799 A (SHELL CANADA LIMITED) 23 December 1993 cited in the application see abstract see page 2, line 32 - line 35 see claim 10 see page 4, line 20 - line 26 see page 5, line 23 - line 35 see page 3, line 17 - line 20 ---	1
A	US 3 901 063 A (NILESHWAR) 26 August 1975 see column 1, line 34 - line 40 ---	1
A	DE 93 04 218 U (PURMO AG) 8 July 1993 see page 4, line 14 - line 16 ---	1
A	US 5 366 012 A (LOHBECK) 22 November 1994 cited in the application see column 2, line 48 - column 3, line 5 see column 3, line 34 - line 57 ---	1
A	DE 15 83 992 B (MANNESMANN A.G.) 9 June 1971 cited in the application see claim 1 ---	1
A	GB 861 683 A (LA SALLE STEEL COMPANY) 22 February 1961 see page 1, line 11 - line 15 see claim 1 ---	1
A	US 5 352 406 A (BARTERI) 4 October 1994 see column 1, line 14 - line 21 see column 1, line 68 - column 2, line 2 see column 2, line 64 - line 68 ---	1
A	US 4 832 757 A (COX) 23 May 1989 see abstract see column 1, line 13 - line 14 see column 1, line 45 - line 51 see column 2, line 34 - line 45 ---	1
A	PATENT ABSTRACTS OF JAPAN vol. 007, no. 281 (C-200), 15 December 1983 & JP 58 157948 A (KAWASAKI SEITETSU KK), 20 September 1983, see abstract --- -/--	1

1

INTERNATIONAL SEARCH REPORT

International Application No
PCT/EP 97/03489

C.(Continuation) DOCUMENTS CONSIDERED TO BE RELEVANT		
Category *	Citation of document, with indication, where appropriate, of the relevant passages	Relevant to claim No.
A	<p>DATABASE WPI Section Ch, Week 8343 Derwent Publications Ltd., London, GB; Class M24, AN 83-798811 XP002020522 & JP 58 157 948 A (KAWASAKI STEEL) , 20 September 1983 see abstract</p> <p>---</p>	1
A	<p>PATENT ABSTRACTS OF JAPAN vol. 015, no. 064 (C-0806), 15 February 1991 & JP 02 290920 A (NIPPON STEEL CORP), 30 November 1990. see abstract</p> <p>---</p>	1
A	<p>DATABASE WPI Section Ch, Week 9103 Derwent Publications Ltd., London, GB; Class H01, AN 91-018662 XP002020523 & JP 02 290 920 A (NIPPON STEEL CORP) , 30 November 1990 see abstract</p> <p>---</p>	1
A	<p>US 5 224 560 A (FERNANDEZ) 6 July 1993 see column 10, line 61 - column 11, line 3</p> <p>---</p>	1
A	<p>US 4 960 643 A (LEMELSON) 2 October 1990 see abstract</p> <p>---</p>	1
A	<p>GB 2 155 950 A (NIPPON STEEL CORPORATION) 2 October 1985 see abstract</p> <p>---</p>	1
A	<p>US 5 014 779 A (MELING) 14 May 1991 cited in the application see column 4, line 12 - line 28</p> <p>---</p>	1
A	<p>US 3 489 220 A (KINLEY) 13 January 1970 cited in the application see claim 1</p> <p>---</p>	1
A	<p>US 3 162 245 A (HOWARD) 22 December 1964 cited in the application see column 2, line 69 - column 3, line 10</p> <p>---</p>	1
A	<p>US 3 203 483 A (VINCENT) 31 August 1965 cited in the application see column 3, line 36 - line 65</p> <p>-----</p>	1

Form PCT/ISA/210 (continuation of second sheet) (July 1992)

INTERNATIONAL SEARCH REPORT

Information on patent family members

Int'l. Application No

PCT/EP 97/03489

Patent document cited in search report	Publication date	Patent family member(s)	Publication date
US 4533405 A	06-08-85	US 4453986 A	12-06-84
CH 180467 A		NONE	
US 4938266 A	03-07-90	JP 1156421 A	20-06-89
		JP 2017505 C	19-02-96
		JP 1156422 A	20-06-89
		JP 2017506 C	19-02-96
		DE 3874100 A	01-10-92
		EP 0320003 A	14-06-89
WO 9325799 A	23-12-93	AU 670948 B	08-08-96
		AU 4324493 A	04-01-94
		CA 2137560 A	23-12-93
		DE 69306110 D	02-01-97
		DE 69306110 T	05-06-97
		EP 0643794 A	22-03-95
		JP 7507610 T	24-08-95
		NO 944721 A	07-12-94
		NZ 253124 A	27-02-96
		US 5348095 A	20-09-94
US 3901063 A	26-08-75	NONE	
DE 9304218 U	08-07-93	NONE	
US 5366012 A	22-11-94	AU 672008 B	19-09-96
		AU 4324593 A	04-01-94
		CA 2137565 A	23-12-93
		DE 69305852 D	12-12-96
		DE 69305852 T	22-05-97
		WO 9325800 A	23-12-93
		EP 0643795 A	22-03-95
		JP 7507611 T	24-08-95
		MD 960219 A	31-05-97
		NO 944746 A	03-02-95
		NZ 253125 A	27-02-96
DE 1583992 B	09-06-71	NONE	

INTERNATIONAL SEARCH REPORT

Information on patent family members

International Application No
PCT/EP 97/03489

Patent document cited in search report	Publication date	Patent family member(s)	Publication date
GB 861603 A		NONE	
US 5352406 A	04-10-94	IT 1263251 B EP 0594935 A NO 931530 A	05-08-96 04-05-94 28-04-94
US 4832757 A	23-05-89	NONE	
US 5224560 A	06-07-93	US 5137097 A AU 9042291 A CN 1061457 A WO 9208033 A US 5199516 A	11-08-92 26-05-92 27-05-92 14-05-92 06-04-93
US 4960643 A	02-10-90	US 5456406 A US 4974498 A US 5096352 A US 5040501 A US 5067826 A US 5255929 A US 5132587 A US 5288556 A US 5284394 A US 5332348 A US 5360227 A	10-10-95 04-12-90 17-03-92 20-08-91 26-11-91 26-10-93 21-07-92 22-02-94 08-02-94 26-07-94 01-11-94
GB 2155950 A	02-10-85	JP 60187663 A JP 60187664 A CA 1239568 A DE 3507124 A FR 2560608 A	25-09-85 25-09-85 26-07-88 12-09-85 06-09-85
US 5014779 A	14-05-91	CA 1322151 A WO 9005831 A AU 621350 B AU 3189889 A DE 3887905 D EP 0397875 A NO 174637 B	14-09-93 31-05-90 12-03-92 12-06-90 24-03-94 22-11-90 28-02-94

INTERNATIONAL SEARCH REPORT

Information on patent family members

International Application No
PCT/EP 97/03489

Patent document cited in search report	Publication date	Patent family member(s)	Publication date
US 3489220 A	13-01-70	NONE	
US 3162245 A	22-12-64	NONE	
US 3203483 A	31-08-65	NONE	

Form PCT/ISA/210 (published family annex) (July 1992)